

The Species of *Lysmata* (Caridea: Hippolytidae) from the Eastern Pacific Ocean

MARY K. WICKSTEN

Department of Biology

Texas A&M University

College Station, Texas 77843-3258

ABSTRACT

Three new species, *Lysmata argentopunctata*, *L. chica*, and *L. nayaritensis*, are described from the eastern Pacific. The species can be distinguished by the rostral teeth, number of free articles of the accessory branch of the flagellum of the antennule, the length of the stylocerite, and the number of articles in the carpus of the second pereopods. The color patterns of *L. argentopunctata* and *L. chica* are characteristic. Including these new species, eight species of *Lysmata* are known from the eastern Pacific. A key and brief diagnoses of all species are provided.

INTRODUCTION

Species of *Lysmata* are known as red rock shrimp, peppermint shrimp or cleaner shrimp. They live among rocks, corals or other hard substrates, and are nocturnally active. Some are cleaners: they remove debris, parasites, diseased tissue, etc. from fishes.

While examining specimens of *Lysmata* spp. from the vicinity of La Paz, Baja California Sur, Mexico, students, colleagues and I encountered specimens that could not be identified with certainty using existing keys (Wicksten 1983, 1990). I compared these specimens with material from among the collections of the California Academy of Sciences (CAS), Los Angeles County Museum of Natural History (LACM), United States Museum of Natural History (USNM), Scripps Institution of Oceanography (SIO), Charles Darwin Research Station, Galapagos Islands, Ecuador (CDRS), and 18 specimens of *L. intermedia* from Isla de Lobos, Gulf of Mexico, Mexico from the Texas A&M University Systematic Collection of Invertebrates (catalogue numbers 2-2141, 2144, 2146-2147, 2149-2152, 2154-2156, 2159 and 3252). With the aid of Carlos Sánchez Ortiz, Luis Hernández and students of the Universidad Autónoma de Baja California Sur (UBCS), La Paz, I collected and photographed fresh specimens of *Lysmata* spp. at four locations in Baja California Sur: Punta Arenas, Calerita, Los Islotes and Cabo San Lucas. With the aid of Rodrigo Bustamante and the staff of the marine laboratory of the Charles Darwin Research Station (CDRS), I collected specimens in the Galapagos Islands. Cleveland Hickman, Jr. of Washington and Lee University, Arlington, Virginia photographed specimens in life and loaned previously collected specimens of *Lysmata* from the Galapagos Is-

lands. Examination of these shrimp revealed four unidentifiable species. One of these, *L. gracilirostris*, has been described in a previous paper (Wicksten 2000).

The descriptions of the new species are given herein, along with a key for identification. Carapace lengths (CL) are given in millimeters. The illustrations are by Michael Hodnett, Texas A&M University.

I found misidentifications and confusion in the literature regarding tropical eastern Pacific species, and have re-examined specimens when possible to confirm their identity. However, some of the identifications in regional checklists and keys remain in doubt. The reader should use the revised key presented here instead of those given by Wicksten (1983, 1990) and double-check the identities of specimens of interest.

I am grateful to Cedric d'Udekem d'Acoz of Braine-l'Alleud, Belgium for sharing with me information on morphology of *L. intermedia*, and reviewing an earlier version of the manuscript. Ken-Ichi Hayashi of the National Fisheries University, Shimonoseki, Japan also reviewed an earlier version of the manuscript.

SYSTEMATICS

Lysmata argentopunctata, new species
(Figs. 1-3)

Lysmata intermedia Kerstitch 1989: 81, fig. 199. (misidentification. not *Hippolysmata intermedia* Kingsley, 1878).

Lysmata californica Wicksten 1983: 27 (in part); Wicksten 1990: 596 (in part); Wicksten 1991: 151 (in

part); Wicksten and Hendrickx 1992: 7 (in part); Wicksten 1996: 287. (misidentifications: not *Hippolyasmata californica* Stimpson, 1866).

Material examined: HOLOTYPE: ov. female, CL 9.2; Morro Colorado, Sonora (28°20'N, 111°18'W), under rocks, 5-10m, 126 January 1982, Alex Kerstitch, LACM 19821381. PARATYPES: PACIFIC COAST OF BAJA CALIFORNIA, MEXICO: Male, CL 5.1; Ridge north of North Rock, Rocas Alijos, 30-35 m, 15 Feb. 1993, Jeff Bozanic, LACM. GULF OF CALIFORNIA, MEXICO: 3 females, CL 7.2-10.0, none ov.; Isla Blanca, Bahfa Bacochibampo, Sonora, 6 m, rubble, 3 July 1978, Alex Kerstitch, LACM 1192-01. 4 ov. females, CL 8.0-10.2, male, CL 7.3; Morro Colorado, Sonora, under rocks, 5-10m, 16 January 1982, Alex Kerstitch, LACM 82-0116. Male, CL 5.6; Bahfa San Gabriel, Isla Espiritu Santo, among coral, 7 March 1937, Yelero III sta. 638-37, USNM cat. no. 237435. 10 females, CL 3.5-6.6, 3 of them ov., 3 males, CL 3.4-5.6, also 2 broken specimens; Bahfa San Gabriel, among coral, 7 March 1937, Yelero III sta. 638-37, USNM cat. no. 237436. Female, CL 3.8, male, CL 4.1, 1 broken specimen; Bahfa San Gabriel, among coral in shallow water, 20 March 1936, Yelero III sta. 604-36, USNM cat. no. 237415. 17 females, CL 2.3-6.1, 10 of them ov., male, CL 3.6; Los Islotes, Baja California Sur, 30 m, among rocks, 27 July 1997, Luis Hernández, UBCS. 5 females, CL 3.3-7.2, 1 of them ov.; Roca Pelicano, Cabo San Lucas, Baja California Sur, 2-5 m, in crack in rock, 20 July 1996, Carlos Sánchez and party, UBCS. GALAPAGOS ISLANDS, ECUADOR: 2 ov. females, CL 8.2-8.6, male, CL 6.3; Isla Albany, 23 August 1997. C.P. Hickman, CDRS 97-348, 97-349. Ov. female, CL 6.2; Devil's Crown (also called Corona del Diablo or Isla Onslow), under rock, 10-18 m, 17 Aug. 1998, CDRS 98-508. Ov. female, CL 5.8; Devil's Crown, 10-15 m, 18 Aug. 1998, CDRS 98-585. Ov. female, CL 7.0; Same location and date, CDRS 98-513. Ov. female, CL 6.6; Isla Mosquera, 8 m, 20 Aug. 1998, CDRS 98-540.

Description. Rostrum straight, not reaching end of second segment of antennular peduncle, with 1-3 dorsal teeth on carapace and 2-3 teeth on rostrum proper, 2 or 3 (usually 2) ventral teeth (Fig. 1A-D, H). Dorsal teeth usually not extending past cornea of eye; bare space between anteriormost spine and apex of rostrum. Carapace with slight forward protrusion above strong antennal spine, and minute pterygostomian spine.

Pleura of first to third abdominal somites rounded, fourth slightly produced, fifth with posterolateral point, sixth somite with posteroventral point (Fig. 1D). Telson (Fig. 1J) slightly shorter than uropods, with 2 pairs dorsolateral spines: one pair near midlength and other closer to apex than to anterior pair. Apex of telson pointed and flanked by two pairs of spines: lateral pair long, mesial pair very short.

Eyes large, cornea darkly pigmented. In juveniles, eyes proportionally larger than in adults.

Antennal peduncle (Fig. 1A, H) short and stout, about 0.5 X length of scaphocerite. Stylocerite reaching or overreaching first segment of antennular peduncle. First segment with tuft of spinules on anterior margin and small ventromesial spine, longer than second segment; second segment longer than third. Antennular flagella almost as long as body. Accessory branch of outer flagellum with 13-17 free articles, free for nearly half of its length, and 13-15 fused articles, densely setose in juveniles but with fewer setae in adults.

Basicerite with sharp anterolateral spine. Scaphocerite (Fig. 1A, H) elongate and slender, 4X long as wide, lateral tooth distinctly overreaching scale. Scale approximately 2X length of antennular peduncle. Flagellum of antenna longer than body.

Mouthparts as figured (Fig. 3). Third maxilliped (Fig. 3A) reaching past end of antennal scale, with exopod reaching well past midlength of antepenultimate segment. Penultimate segment short, less than 0.5X length of ultimate segment. Ultimate segment setose, especially in juveniles, with 4-5 spines at and near apex. Epipod present.

First to fourth pereopods with epipods, all reaching to or beyond end of antennal scale when extended. First pereopod (Fig. 2A) short and chelate, fingers of chela less than 0.5X palm (Fig. 1E). Carpus at least as long as chela. Merus slightly longer than carpus. Ischium short. Second pereopod (Fig. 2B) elongate. Fingers of chela (Fig. 1F) shorter than palm. Carpus with 20-27 articles (usually 23-25). Merus with 9-12 indistinct articles, ischium with 6 indistinct articles. Third pereopod (Fig. 2C) with dactyl about 0.25 X propodus, biunguiculate, with 2-3 smaller spines on flexor margin. Propodus with 7-9 spinules along flexor margin. Carpus about 0.7 X propodus, with 2-3 minute spinules on flexor margin. Merus with 4-7 ventrolateral spines. Ischium short. Fourth pereopod (Fig. 2D) similar to third, but shorter, merus with 3-7 ventrolateral spines. Fifth pereopod (Fig. 2E) shorter still, merus with 2-4 ventrolateral spines. Meral spines fewer or missing from specimens with regenerating appendages.

First pleopod (Fig. 3I) with endopod slender and short. Second pleopod (Fig. 1I, 3G, H) with appendix interna. Appendix masculina (Fig. 3G, H) about 2X length of appendix interna. Outer uropod (Fig. 1J) with posterolateral spines. Carapace length of female to 10.2 mm, male to 7.9.

Color in life. Antennae and appendages red. Body with dark greenish or red longitudinal lines interspersed

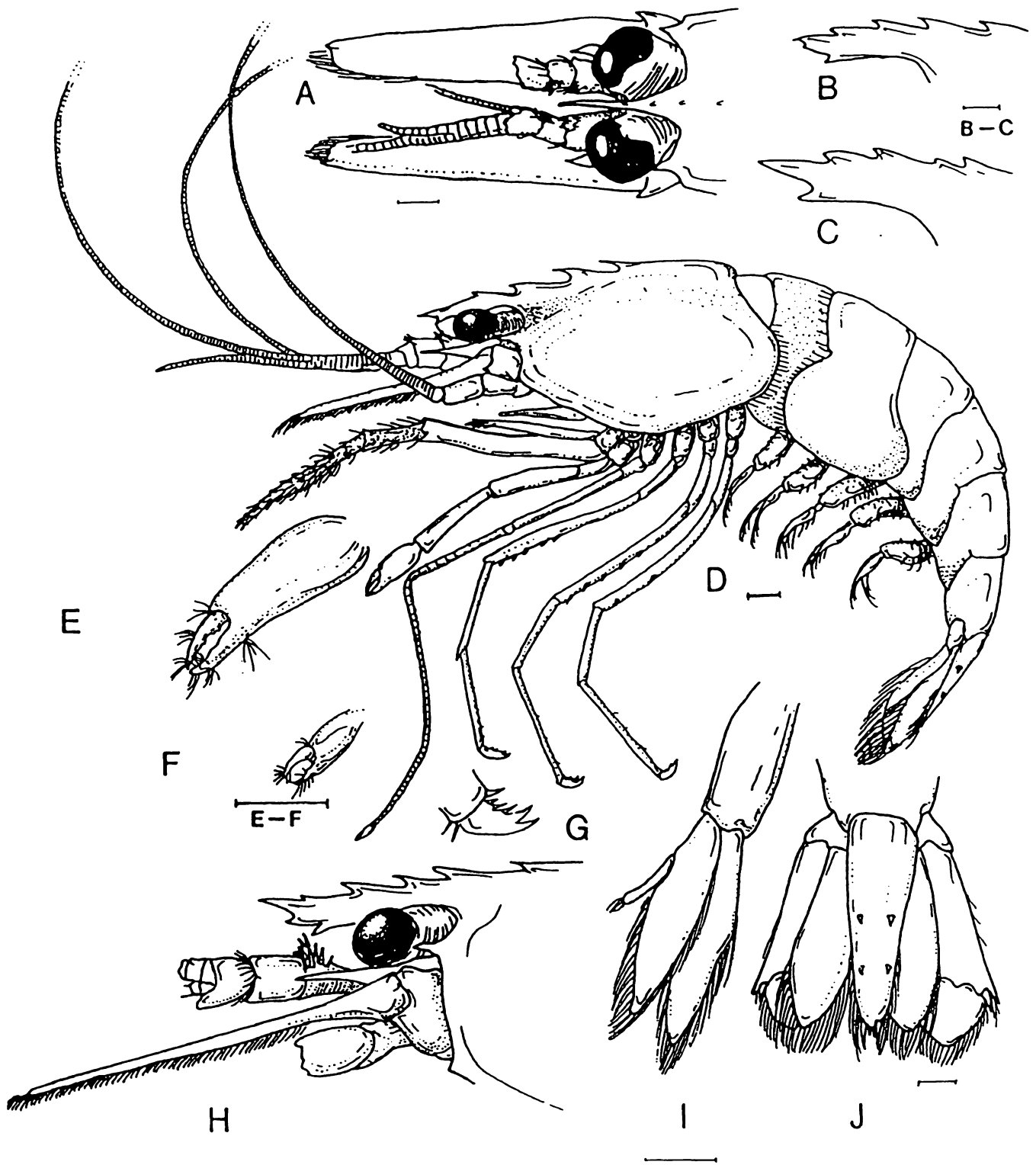

Fig. 1. *Lysmata argentopunctata*, n. sp. Female, CL8.0, Morro Colorado. Sonora, Mexico. A, frontal region in dorsal view; B, C, two shapes of the rostrum from paratype specimens; D, entire animal in lateral view; E, detail of chela of first pereopod; F, detail of chela of second pereopod; G, dactyl of third pereopod; H, frontal region in lateral view; I, female second pereopod; J, telson and uropods. Scales = 1 mm.

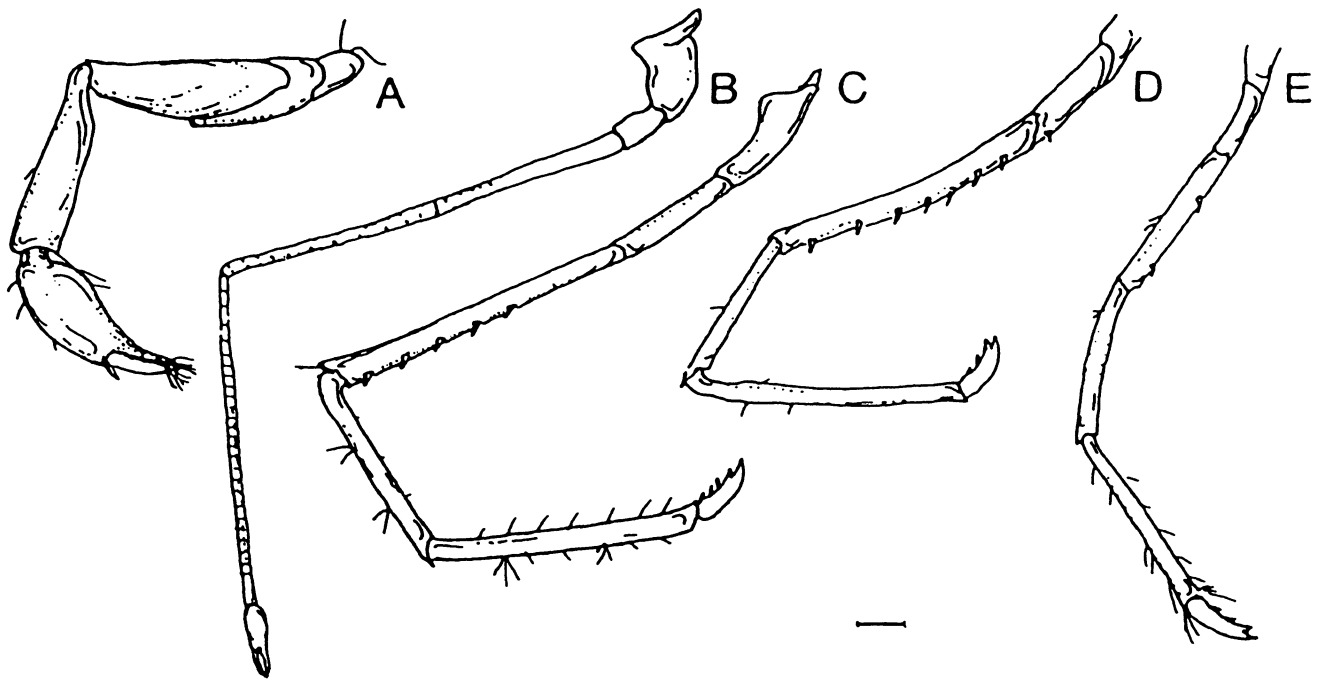

Fig. 2. *Lysmata argentopunctata* n. sp. Female, CL 9.9, Morro Colorado, Sonora. A, first pereopod; B, second pereopod; C, third pereopod; D, fourth pereopod; E, fifth pereopod. Scale = 1 mm.

with alternating longitudinal lines of silvery white spots. (See Kerstitch 1989, photo 199, p. 81, as *L. intermedia*: I have reexamined the specimens that were photographed, and they belong to the new species). My photographs of living specimens from the Galapagos and the Gulf of California show the same color pattern. **Range.** Rocas Alijos, Pacific coast of Mexico; Morro Colorado, Gulf of California to Galapagos Islands. **Etymology.** The specific epithet is derived from "argentum", meaning silver, and "punctata", meaning spotted, to refer to the living coloration of the animal.

Remarks. *Lysmata argentopunctata* resembles *L. intermedia* (Kingsley, 1878) of the western Atlantic and Caribbean, and has so been misidentified. (e.g., Wicksten, 1983, specimens from Bahía Bacoichibampo). The number of carpal articles, the spines of the carapace and rostrum, and the length and shape of the parts of the antennular peduncle and scaphocerite are similar. However, the accessory flagellum of *L. intermedia* is free for only about 3-5 articles, while in *L. argentopunctata*, it is free for up to 17 articles, more than half of its length. The rostrum of *L. intermedia* has dorsal teeth equally spaced up to the apex, while that of *L. argentopunctata* has a bare space near the apex.

Because of the similarity in the rostrum, *L. argentopunctata* and *L. californica* have been confused in the past. The specimen from the Rocas Alijos was previously reported as *L. californica* by Wicksten

(1996). I re-examined this specimen, and found that it belongs to *L. argentopunctata*. However, the accessory branch of the flagellum of the antennule in *L. argentopunctata* has at least 13 free articles, while that of *L. californica* is fused completely or free for only one segment. The stylocerite of *L. argentopunctata* reaches at least to the end of the first segment of the antennular peduncle while in *L. californica* it is much shorter. The color patterns are different: *L. argentopunctata* has silvery spots and diffuse longitudinal white stripes, lacking in *L. californica* which is also predominantly marked with red streaks.

Lysmata argentopunctata is very similar to *L. trisetacea*, which also occurs in the tropical eastern Pacific. The shape of the rostrum and number of carpal articles of the second pereopod are very similar. However, in *L. argentopunctata*, the rostrum usually reaches the middle of the second segment of the antennular peduncle; in *L. trisetacea*, it barely reaches beyond the end of the first segment. The scaphocerite of *L. argentopunctata* has a spine that markedly exceeds the blade, which is 4x as long as wide; while in *L. trisetacea*, the spine barely exceeds the blade if at all, and the blade is 3x as long as wide. In *L. argentopunctata*, the upper flagellum of the antennule has 13-17 slender free articles, while *L. trisetacea* has 7-10 wide free articles (usually 8). The merus of the third pereopod of *L. argentopunctata* has 4-7 ventrolateral spines, while *L. trisetacea* has two or three ventrolateral meral spines.

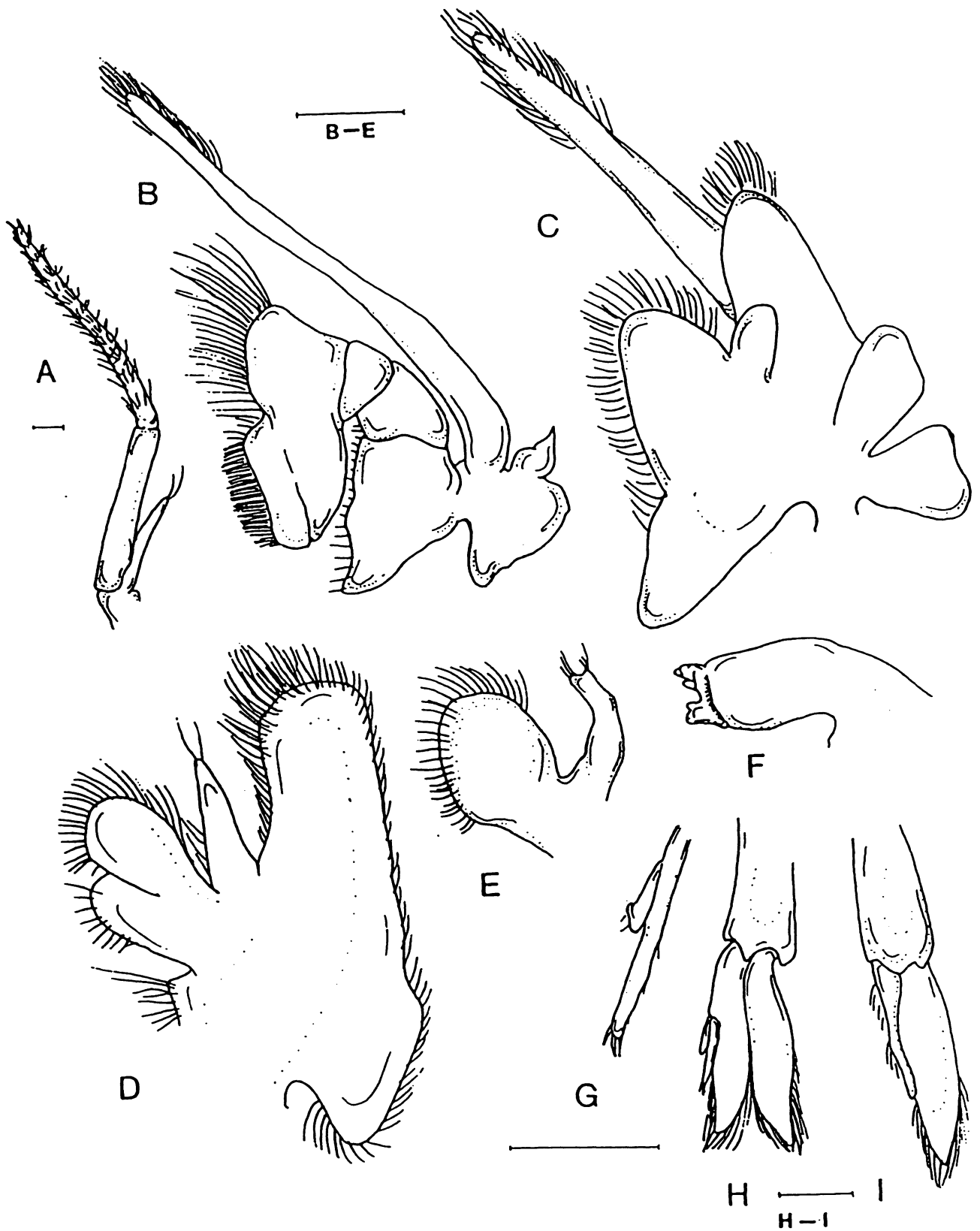

Fig. 3. *Lysmata argentopunctata* n. sp. Female, CL 9.9, Morro Colorado, Sonora. A, third maxilliped; B, second maxilliped; C, first maxilliped; D, second maxilla; E, first maxilla (broken); F, mandible. G-I, male, CL 7.3, Morro Colorado, Sonora. G, detail of appendices masculina and interna; H, second pleopod; I, first pleopod. Scales = 1 mm.

Lysmata argentopunctata was collected under rocks, in cracks or among branches of corals. It is a common species of *Lysmata* in the southern Gulf of California and shallow subtidal areas of the Galapagos Islands.

Lysmata californica (Stimpson, 1866)

(Fig. 4A)

Hippolysmata californica Stimpson, 1866: 48; Holmes 1900: 180, pl. 2, fig. 38; Rathbun 1904: 56; Schmitt 1921: 49, fig. 27; Holthuis 1947: 19; Limbaugh 1961: 44.

Lysmata californica Chace and Abbott 1980: 569, fig. 23.8; Standing 1981: 780; Wicksten 1983: 27; Debelius 1984: 105; Ricketts et al. 1985: 173, fig. 144; Kerstitch 1989: 81, fig. 198; Wicksten 1990: 596; Wicksten and Hendrickx 1992: 7; Jensen 1995: 51, fig. 90; Chace 1997: 73.

Material examined. U.S.A.: Ov. female, CL 18.2. Moss Landing Harbor, Monterey Bay, California, 27 Feb. 1979, B. Larsson and M. Carlin, CAS 013401. MEXICO: Ov. female, CL 6.7; north of Punta Entrada, Bahía Magdalena, subtidal, 2 Nov. 1971, Searcher station 288, LACM. Ov. female, CL 12.9; Puerto Peñasco, Sonora, 1966, Peter Castro, CAS 073781. 4 females, CL 7.3-12.4, 2 of them ov., male, CL 7.6; Roca Consag, Gulf of California, 24 March 1937, 18-46 m, Yelero III sta. 719-37, USNM 237449. Female, CL 9.2; Guaymas, Sonora, 3-6 m, 28-29 March 1978, Alex Kerstitch, LACM.

Recognition characters. Rostrum slender, strongly ridged on sides, bent downward near base, reaching at most slightly beyond end of second segment of antennular peduncle, with 5-7 dorsal and 2-4 ventral teeth. Carapace with faint obtuse lobe above sharp antennal spine and small pterygostomial spine. First segment of antennular peduncle with closely set spinules on distal margin. Stylocerite not reaching end of first segment of peduncle. Flagella of first antenna longer than body. Accessory branch of outer flagellum completely fused or free for only one segment, fused part consisting of 26-30 segments. Basicerite of second antenna with sharp lateral spine. Scaphocerite overreaching antennular peduncle by nearly length of last segment of peduncle, spine strongly overreaching blade. Third maxilliped with exopod reaching well past midlength of antepenultimate segment. Second pereopod with 25-32 articles (usually 27-29) in carpus. Third to fifth pereopods with stout, biunguiculate dactyls and 2-3 spines on flexor border; merus of third pereopod with 6-7 ventrolateral spines, fourth pereopod, with 5-6 ventrolateral meral spines; fifth pereopod,

with 3-4 ventrolateral meral spines. Carapace length of female to 18.2, male to 12.7.

Color in life. Banded with longitudinal red stripes, sometimes with greenish tinge. See guidebooks by Debelius (1984: 105), Kerstitch (1989: 81, fig. 198) and Jensen (1995: 51, fig. 90) for color photos in life. At night, the corneas of the eyes reflect a golden color.

Habitat. Tidepools, kelp beds and rocky reefs; intertidal to over 60 m (Chace and Abbott 1980).

Range. Rarely as far north as Tomales Bay, California but usually south of Point Conception; south to Magdalena Bay, Baja California, Mexico; Gulf of California at Consag Rock, Puerto Peñasco and Guaymas. Type locality San Diego, California (Stimpson, 1866). Previous reports from the Galapagos Islands are based on misidentifications.

Remarks. I have observed *L. californica* in tidepools and on rocky reefs at San Pedro and along the eastern side of Santa Catalina Island, California (U.S.A.) It often lives in swarms under rocks or in crevices. It is most active at night and acts as a cleaner or scavenger when it cohabits the holes of the California moray, *Gymnothorax mordax* (See Limbaugh 1961, for photographs). This species may disperse widely by clinging to drifting kelp. It also may be released by fishermen who use it as live bait in southern California.

In previous publications, *L. californica* has been confused with other species. Brusca (1980) provided an illustration of the species and information on its natural history. He mentioned that there might be two additional species of *Lysmata* in the Gulf of California; however, the characters he provided to distinguish these two species were insufficient for identification, even to genus. I have been unable to examine the specimens on which these species were based. Abele (1975: 81) considered a specimen taken at the Galapagos to be *L. californica*, but it seems to have been *L. chica* n. sp. (See discussion under that species).

Lysmata chica new species

(Figs. 5-7)

?*Lysmata intermedia* Sivertsen 1933: 5, pl. II, figs. 9-15; Abele 1975: 81; Chace 1972: 128; Wicksten and Méndez 1983: 86, figs. 35, 36; Wicksten 1991: 150. not *Hippolysmata intermedia* Kingsley, 1878: Caribbean-Atlantic species (See remarks).

Lysmata californica Wicksten 1991: 151 (in part); Wicksten and Hendrickx 1992: 7 (in part); (misidentification: not *Hippolysmata californica* Stimpson, 1866).

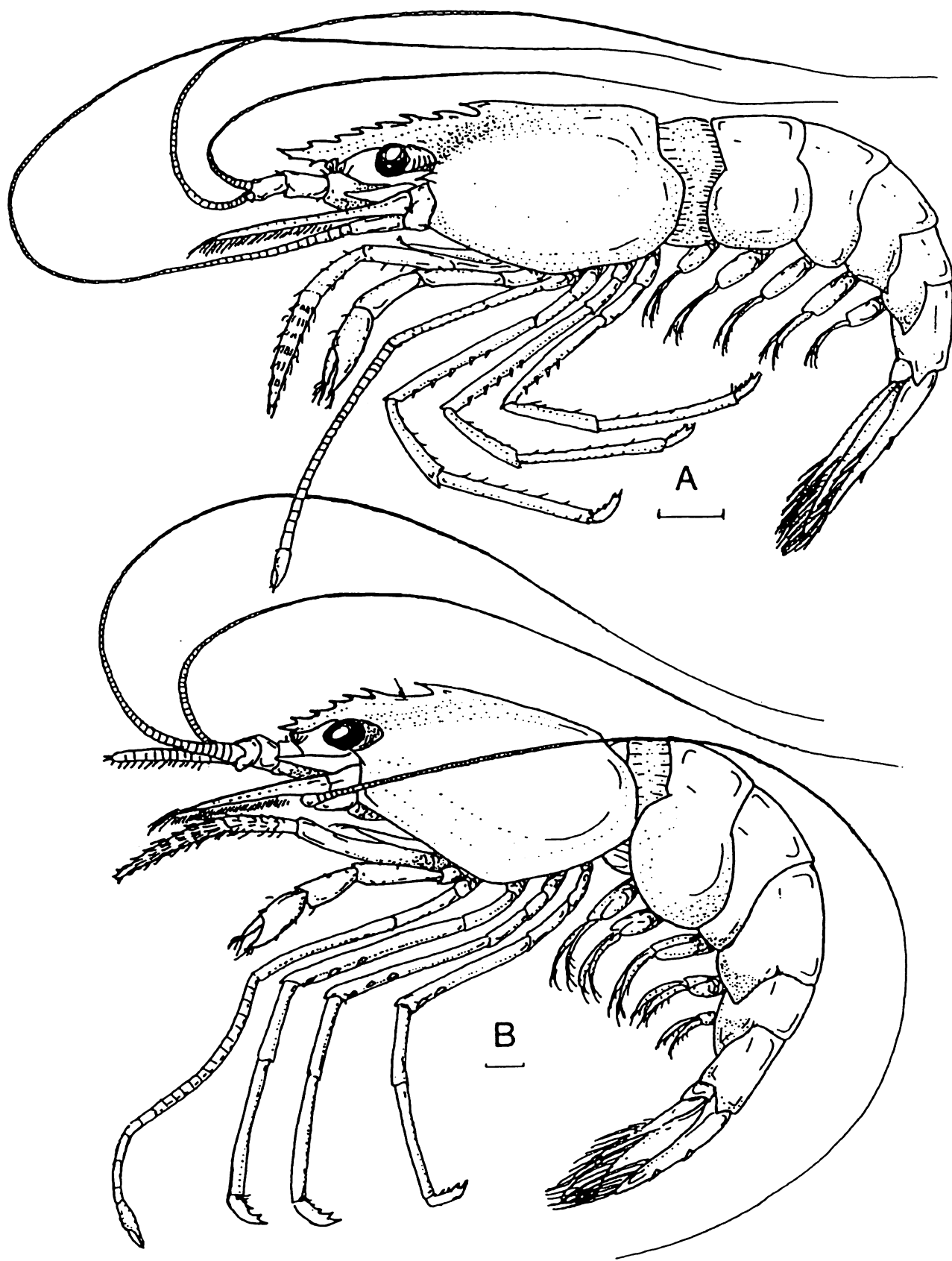

Fig. 4. A, *Lysmata californica* (Stimpson). Female, CL 12.4, Consag Rock, Gulf of California, Mexico; B, *Lysmata galapagensis* Schmitt. Male, CL 7.1, Mazatlán Sinaloa, Mexico. Scale A = 3 mm B = 1 mm

Material examined.—HOLOTYPE: male, CL 4.6. Bahía Cartago, Isla Isabela (Albemarle Island), Galapagos (0°34'N, 90°58'W), shore, 22 Jan. 1938, *Velero III* sta. 800-38, USNM cat. no. 237416. PARATYPES: ECUADOR: female, CL 4.2; La Libertad, USNM cat. no. 237418. GALAPAGOS ISLANDS: 4 females, CL 2.2-6.0, 1 of them ov., 2 males, CL 4.5-5.0. Bahía Cartago, north shore, Isla Isabela, sand, 14 Feb. 1933, *Velero III* sta. 76-33, USNM cat. no. 237439. 3 females, CL 4.0-5.2, none of them ov. Bahía Cartago, north shore, rock, 22 Jan. 1938, *Velero III* sta. 800-38, USNM cat. no. 237416. Female, CL 5.2. Post Office Bay, Isla Santa María (Charles Island), 5 Feb. 1933, no station number, USNM cat. no. 229729. Ov. female, CL 6.3; Black Beach, Isla Santa María, shore, rock, 19 Jan. 1934, *Velero III* sta. 166-34, USNM cat. no. 237437. 4 females, CL 3.3-7.0, 3 of them ov., male, CL 4.6; Black Beach, shore, rock, 27 Jan. 1933, *Velero III* sta. 33-33, USNM cat. no. 237419. Female, CL 4.6; Devils' Crown (Isla Onslow), crater, with *Pavona* coral, 23 Jan. 1938, *Velero III* sta. 804-38, USNM cat. no. 237438. 5 females, CL 3.5-4.9, 2 of them ovigerous, [carapace only], CL 4.2; Isla Santa Fé (Barrington Island), shore, among *Pocillopora* coral, 26 Jan. 1938, *Velero III* sta. 811-38, USNM cat. no. 237432. Ov. female, CL 5.0, male, CL 6.0; Bahía Academy, Isla Santa Cruz (Indefatigable Island), shore, rock, 7 Dec. 1934, *Velero III* sta. 314-35, USNM cat. no. 237417. Female, CL 4.8; Bahía Academy, K. Krubber, no date, LACM. Ov. female, CL 4.6; Bahía Academy, mid-littoral, 16 May 1995, C.P. Hickman and party, CDRS 95-11. Ov. female, CL 4.9; Bahía Academy, in front of CDRS, shore, 18 Aug. 1997, CDRS 97-322. Female, CL 5.9; Bahía Academy, shore, 18 Aug. 1997, C. Hickman, CDRS 97-323. 6 females, CL 3.5-5.1, 3 of them ov.; Isla Pinzón (Duncan Island), shallow water, coral, 15 Feb. 1933, *Velero III* sta. 80-33, USNM cat. no. 237434.

Description. Rostrum (Fig. 5A-C) with 6-7 dorsal teeth, 3 of them usually on carapace proper, and 1-3 (usually 2) ventral teeth, reaching at least to second segment of antennular peduncle. Carapace (Fig. 5A, B) with large antennal spine, either no pterygostomial spine or extremely small one. Pleura of first and second abdominal somites rounded, pleura of third somite angular, pleura of fourth somite with posterolateral point, pleura of fifth somite with posterolateral tooth, sixth somite with blunt tooth-like areas flanking insertion of uropod (Fig. 5A). Telson (Fig. 5D) with 2, rarely 3, pair dorsolateral spines (sometimes not bilaterally symmetrical), pointed apex, 2 pairs terminal spines, lateral pair short and mesial pair long; and long setae.

Eye darkly pigmented, rounded.

Stylocerite as long as or longer than first segment of antennular peduncle (Fig. 5B, C). First segment longest of segments of antennular peduncle, with tuft of spinules on distal margin. Distal margins of second and

third segments also with spinules. Accessory branch of outer flagellum of antennule with 3-6 free articles (usually 5) and 10-11 fused articles. Basicerite with small spine on ventrodorsal margin (rarely absent). Scaphocerite 4X long as wide. Spine of scaphocerite longer than blade, blade with rectangular distal margin and exceeding rostrum and antennular peduncle. Flagella of both antennae at least as long as body.

Mouthparts as figured (Fig. 7). Third maxilliped (Fig. 7A) about as long as scaphocerite, with exopod and epipod; exopod reaching past midlength of antepenultimate segment. Antepenultimate segment about 3X as long as penultimate segment. Ultimate segment 2.3X length of penultimate segment, setose and ending in sharp claw-like spines. Third maxilliped slightly overreaching scaphocerite.

First to fourth pereopods (Fig. 6 A-D) with epipods. First pereopod (Fig. 6A) chelate, not as long as third maxilliped. Fingers of chela 0.5X length of palm. Carpus slightly longer than palm, merus longer than carpus, ischium without spine. Second pereopod (Fig. 6B) long and slender, chelate, with 23-28 carpal articles and 10-13 faint annulations in merus. Third to fifth pereopods (Fig. 6C-E) with short, biunguiculate dactyls, 2-3 smaller spines on flexor margin proximal to larger spines. Third pereopod larger than fourth or fifth. Propodus 4X dactyl, with 4-7 setae on flexor margin; carpus 0.7X propodus, with 2 minute spinules on flexor margin; merus 1.5X carpus, with 3-4 ventrolateral spines; ischium about 0.3X length of merus. Fourth pereopod and fifth pereopods similar in shape to third pereopod, fourth with 3-4 ventrolateral meral spines and fifth with no more than 3 ventrolateral meral spines.

First pleopod (Fig. 7G) with endopod slender and short. Second pleopod (Fig. 7H-J) with appendix interna. Male with appendix masculina much longer than appendix interna (Fig. 7H, I). Uropods (Fig. 5D) longer than telson, exopod with spine on outer margin by suture. Carapace length of male and female to 6.0 mm. Color in life. Antennal flagella red. Pereopods red with white band near dactyl. Carapace with red to brown transverse bands, posterior margin creamy white. Abdominal somites with transverse bands of brown and cream to pink. Dark vertical bands on first and third abdominal somites. Second abdominal somite with dark marks along posterolateral margin, and often with mark extending toward anterolateral margin, producing shape of inverted Y. (Color photos of specimens CDRS 97-322 and 97-323, Cleveland Hickman, Jr.)

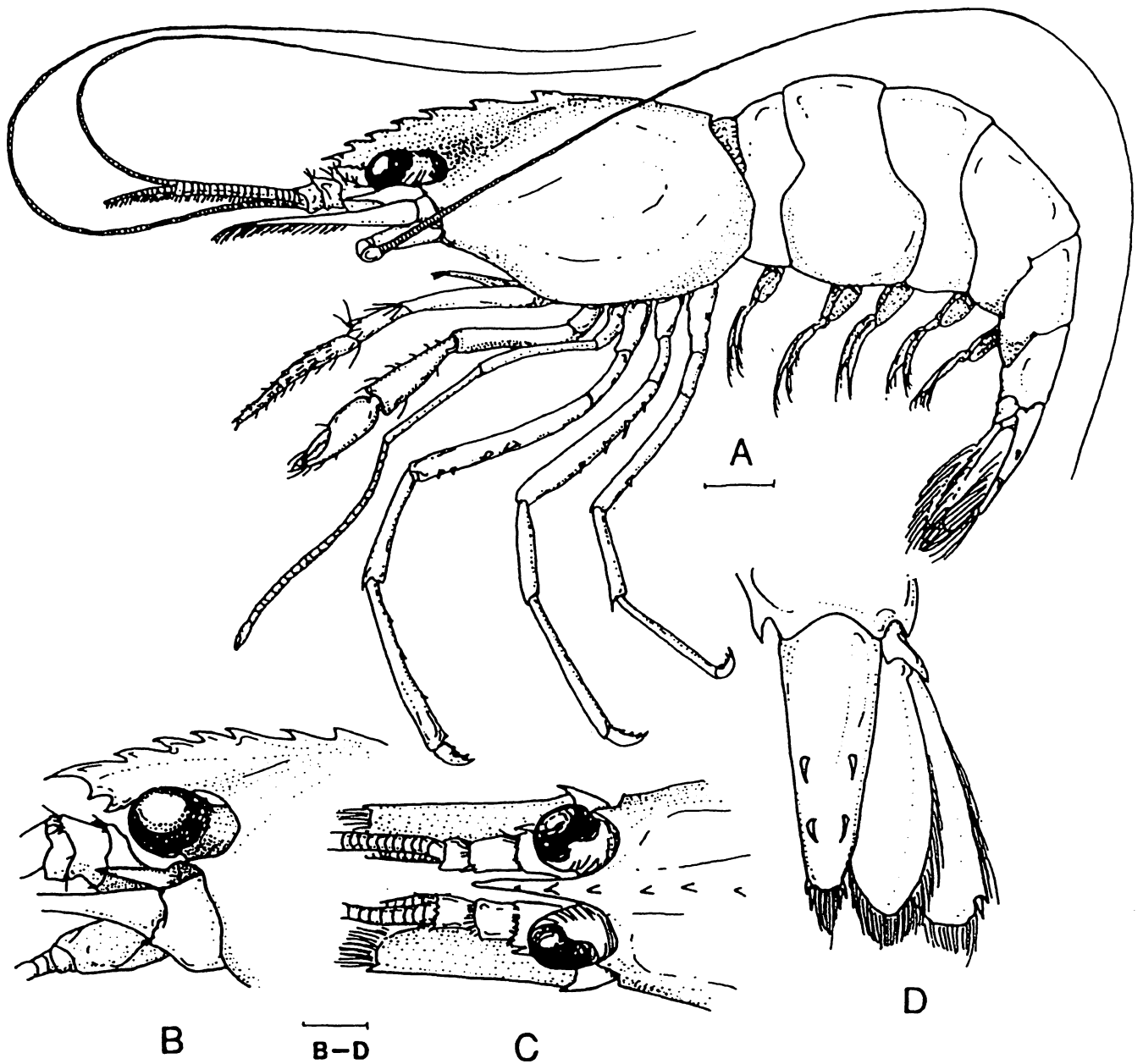

Fig. 5. *Lysmata chica* n. sp. Female, CL 4.4. Bahía Academy, Galapagos Islands. A, entire animal in lateral view; B, frontal region in lateral view; C, frontal region in dorsal view; D, telson and uropod. Scales = 1 mm.

Range. Galapagos Islands, possibly Peru (See remarks).

Etymology. The specific epithet is the Spanish word "chica", to be treated as a noun in apposition and feminine in gender. The word means "little one"; in Mexico, the word has a connotation of cuteness. The name is given because of the small size of the shrimp.

Remarks. *Lysmata chica* closely resembles specimens of *L. intermedia* (Kingsley, 1878) from the Gulf of Mexico, Caribbean and western Atlantic. I com-

pared the specimens of the new species to specimens of *L. intermedia* from Isla de Lobos, Gulf of Mexico, Mexico. In *L. chica*, the third maxillipeds barely exceed the scaphocerite; in *L. intermedia*, they surpass it by nearly the length of the ultimate segment. *Lysmata chica* has more robust and shorter appendages than *L. intermedia*. In most specimens of *L. chica*, the carpus of the first pereopod is about as long as the chela; in *L. intermedia*, the carpus usually is longer than the chela. In *L. chica*, the meral spines of the third pereopod are in a single line extending ventrolaterally, in *L.*

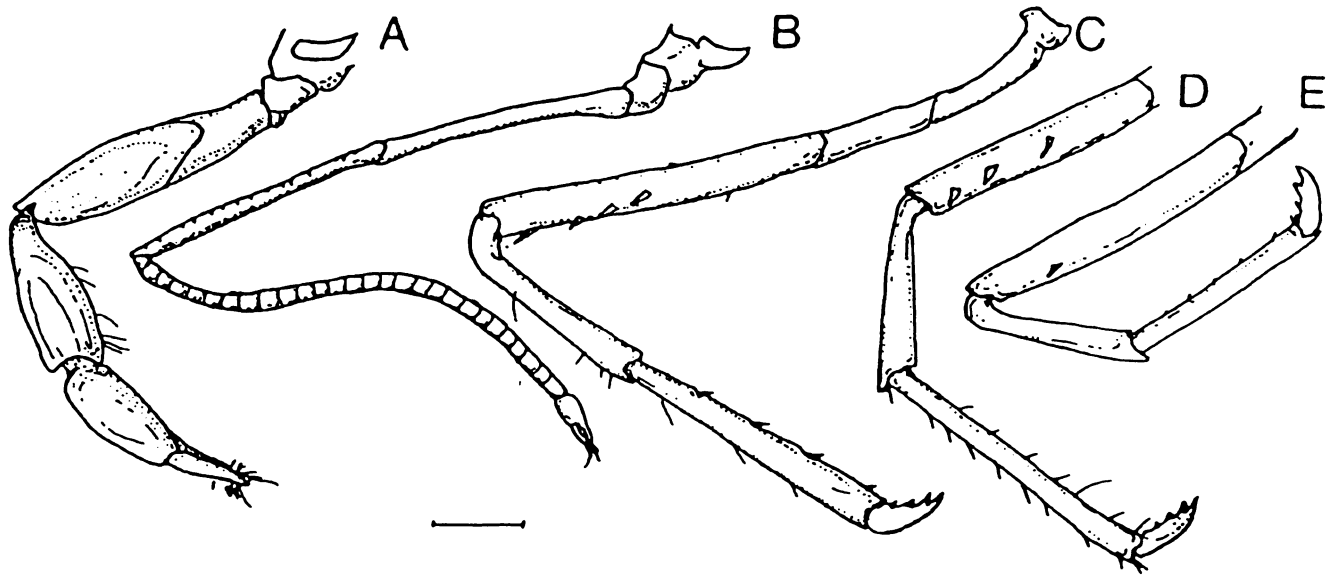

Fig. 6. *Lysmata chica* n. sp. Female, CL 5.1, Isla Pinzón, Galapagos Islands. A, first pereopod; B, second pereopod; C, third pereopod; D, fourth pereopod; E, fifth pereopod. Scale = 1 mm

intermedia, there are two spines located ventral to the others on the proximal half of the merus. Unfortunately, the color pattern of *L. intermedia* is not known and cannot be compared with the characteristic color pattern of *L. chica*. The similarity in size and shape of the two species strongly suggests that they are sibling species derived by vicariance from a common ancestor that ranged across the ancient Panamic Seaway.

I have not been able to re-examine specimens from the Galapagos identified as *L. intermedia* by Sivertsen (1933) and mentioned by Abele (1975: 81); however, Sivertsen's illustrations closely resemble *L. chica*. Chace (1972) and Wicksten (1991) included the Galapagos Islands in the range of *L. intermedia* based on Sivertsen's record. The specimens from Peru identified as *L. intermedia* by Wicksten and Méndez (1983) may be *L. chica*, but these, too, need to be re-examined. Specimens reported from the Galapagos as *L. californica* by Wicksten (1991) are a mixture of *L. chica* and *L. gracilirostris*.

Lysmata galapagensis Schmitt, 1924

(Fig. 4B)

Lysmata galapagensis Schmitt, 1924: 165, fig. 41; Hult 1939: 6; Holthuis 1947: 219; Abele 1975: 81; Wicksten 1979: 629; Wicksten 1983: 27; Hendrickx and Wicksten 1987: 14; Hendrickx 1989: 246; Kerstitch 1989: 82, fig. 200; Wicksten 1990: 596.; Wicksten 1991: 150; Wicksten and Hendrickx 1992: 7; Chace, 1997: 72.

Material examined. MEXICO: Male, CL 6.1. South end of Punta Sabalo, Mazatlán, Sinaloa, tidepool, 0.3-2 m, 20 March 1968, J. McCosker, SIOC3352. 2 males, CL 6.8-7.1; Same site and date, SIOC2629. Male, CL 5.9; Arrecife San Lorenzo, Acapulco, Guerrero, Carl Hubbs 1946, sta. H46-234, LACM. PANAMA: male, CL 5.0; Bahía Honda, shore, rock, 1 March 1938, Yelero III sta. 861-38. GALAPAGOS ISLANDS, ECUADOR: female, CL 3.2; Isla Osborn in Bahía Gardner, Española Island, shore rock, 19 Dec. 1934, Yelero III sta. 359-34, LACM. Female, CL 3.5, male, CL 4.1; Bahía Sullivan, Isla Santiago, shore, 21 Jan. 1938, Yelero III sta. 796-38, LACM.

Recognition characters. Rostrum reaching or surpassing distal margin of first segment of antennular peduncle, with 5-7 dorsal teeth, 1-2 of them on carapace proper, and one ventral tooth near apex; long setae on dorsal crest between posteriormost and next most posterior dorsal teeth. Carapace with prominent antennal spine, no pterygostomial spine; pterygostomial margin obtuse. Stylocerite slightly overreaching first segment of antennular peduncle. First segment of antennular peduncle with tufts of spinules on distal margin; longer than second segment; third segment shortest. Free part of accessory flagellum of outer antennular flagellum with 5-7 articles, fused part with 6-13 articles. Basicerite with lateral spine. Base of antennal flagellum at most barely reaching end of first segment of antennular peduncle. Scaphocerite longer than antennular peduncle by nearly 0.5X of its length.

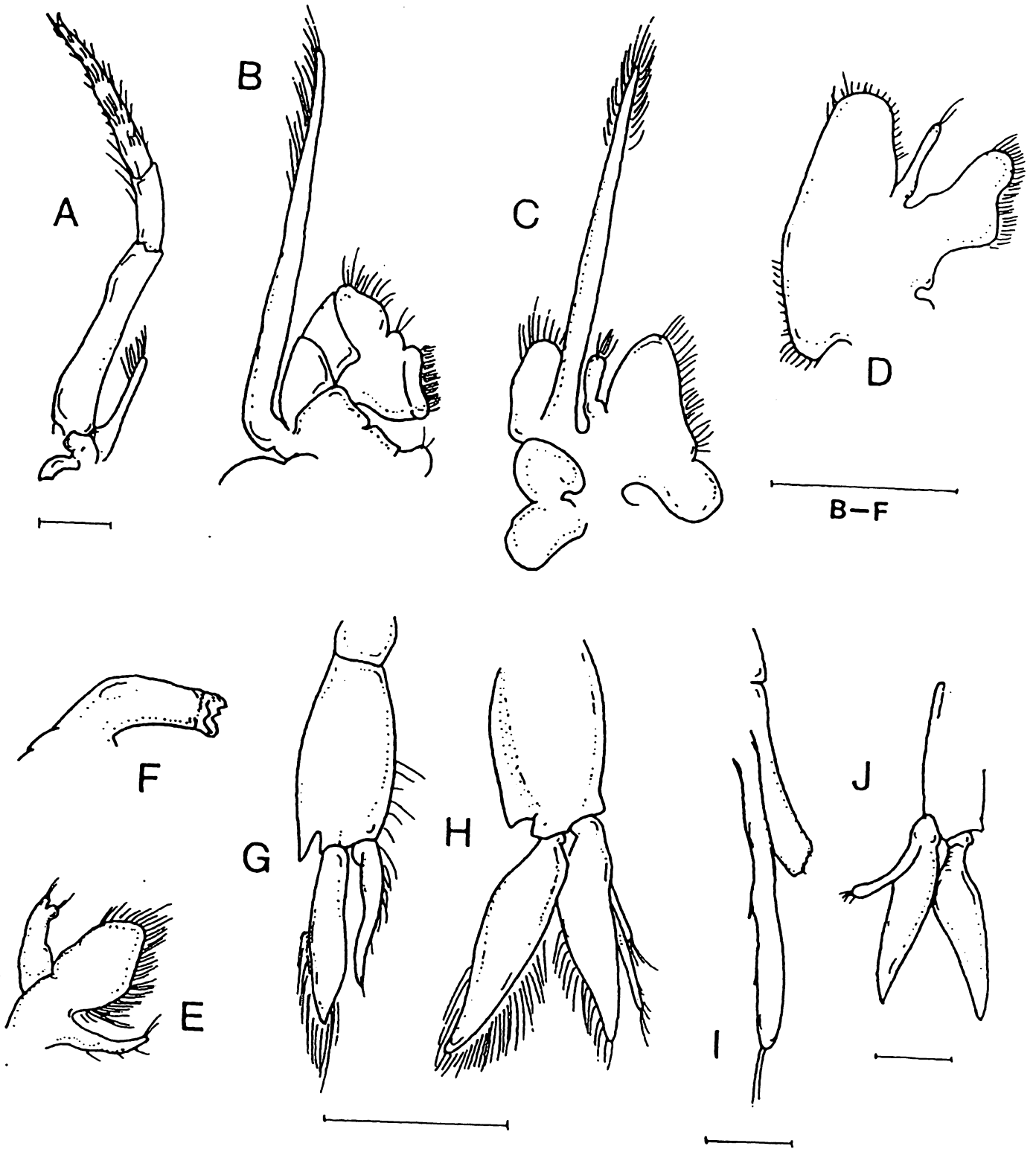

Fig. 7. *Lysmata chica* n. sp. Female, CL 5.1, Isla Pinzón, Galapagos Islands. A, third maxilliped; B, second maxilliped; C, first maxilliped; D, second maxilla; E, first maxilla; F, mandible; J, second pleopod. Scales = 1 mm. G-I, male, CL 5.0, Bahía Cartago, Isla Isabela. G, first pleopod; H, second pleopod; I, detail of appendices interna and masculina. Scales G,H, J = 1 mm; I = 0.2 mm.

spine slightly shorter than to slightly overreaching blade. Third maxilliped setose, reaching beyond scaphocerite by about length of its ultimate segment; with exopod reaching about to midlength of antepenultimate segment. First pereopod short and stout. Second pereopod with small chela, carpus with 17-19 segments, merus with 7-9 faint annulations, ischium with 2 faint annulations. Third pereopod larger than fourth or fifth pereopods, dactyl biunguiculate and with 2 smaller spines on flexor margin, with 2-3 ventrolateral meral spines. Fourth and fifth pereopods similar to third pereopod but smaller; merus of fourth pereopod with 2-3 ventrolateral meral spines, merus of fifth pereopod with no more than 2 ventrolateral meral spines. Female carapace length to 6.2 mm, male to 4.8.

Color in life. Antennae and appendages red. Carapace reddish to brown, with three white marks on dorsal surface, and blotches of white to pale pink along lateral surfaces. Abdomen mostly brownish-red, with two long and one short white stripes on somites 1-4; large pale circular spot on pleuron of first somite. Telson and uropods with white tips (Kerstitch 1989, fig. 200).

Habitat. Rocky areas and among mangroves; intertidal to 10 m.

Range. Bahía Magdalena, Baja California; Gulf of California, southwestern Mexico to Acapulco; Panamá; Galapagos Islands. Type locality northeast of Eden, Isla Santa Cruz, Galapagos Islands (Schmitt 1924).

Remarks. *Lysmata galapagensis* is an easily recognized species. The color in life is distinctive. The large seta between the most posterior rostral teeth is easily discernible.

In Schmitt's original description (1924), no mention is made of spines on the meri of the third to fifth pereopods, nor are they shown in Fig. 41g. The drawing may show the third pereopod from the mesial aspect. The spines are on the lateral surface.

Lysmata gracilirostris Wicksten, 2000
(Fig. 8B)

Lysmata californica Wicksten 1991:151 (in part); (misidentification: not *Hippolysmata californica* Stimpson, 1866).

Lysmata gracilirostris Wicksten, 2000: 207, figs. 1-3.

Material examined. MEXICO: Broken specimen, CL 4.2; Off Bahía Braithwaite, Isla Socorro, 129-138 m, rocks and shell, 18 March 1939, *Velero III* sta. 925-39, LACM. COSTA RICA: 2 females, CL 5.8-6.3, neither of them ov.; Gulf of Papagayo, 81-86 m, 2 April 1978, *Alpha Helix*, SIO cat. No. C4062. PANAMA: female, CL 4.9, off Isla Jicarita, 44 m,

shelly substrate, 20 Feb. 1934, *Velero III* sta. 240-35, USNM cat. No. 237447. GALAPAGOS ISLANDS, ECUADOR: female, CL 6.0, Tagus Cove, Isla Isabela, in roach trap, 15 Jan. 1934, University of Southern California (USC) field party, no station number, USNM cat. No. 237445. Female, CL 6.4, Black Beach, Isla Santa María, rocky shore, 18 Jan. 1934, USC field party, *Velero III* sta. 162-34, USNM cat. No. 237448.

Recognition characters. Rostrum with 6 dorsal teeth, 2 of them on dorsal midline of the carapace and 4 on the rostrum proper; tip bifid, 5-6 ventral teeth, reaching to or just past end of second segment of antennular peduncle. Carapace with prominent antennal spine and small pterygostomian spine. Stylocerite not reaching end of first segment of antennular peduncle, reaching end of cornea. First segment of antennular peduncle longest, with small spinules on distal margin. Outer flagellum with accessory flagellum fused throughout its length, fused portion consisting of 20-25 articles. Basicerite with sharp lateral spine. Thickened base of antenna about as long as first segment of antennular peduncle. Scaphocerite with spine distinctly longer than blade, overreaching antennular peduncle by at least length of last segment of antennular peduncle. Third maxilliped with exopod reaching about 0.5X length of antepenultimate segment. Carpus of second pereopod with 28-31 articles. Third pereopod with slender biunguiculate dactyl having 2-3 small spines on flexor margin, merus with 5-6 ventrolateral spines. Fourth pereopod similar to third but shorter, with 2-3 ventrolateral meral spines; fifth pereopod shorter still, with 2 ventrolateral meral spines. Female carapace length to 6.3 mm.

Color in life. Not reported.

Habitat. Mostly subtidal, 0-138 m, among rocks and shells.

Range. Isla Socorro, Mexico to Galapagos Islands. Type locality Gulf of Papagayo (Wicksten, 2000).

Remarks. *Lysmata gracilirostris*, like *L. californica*, has the accessory branch of the inner antennular article fused and the stylocerite shorter than the first segment of the antennular peduncle. However, the pereopods are much more slender and elongate, the rostrum is longer, and the size much less than in *L. californica*.

Lysmata nayaritensis new species
Figs 9-11

Lysmata intermedia Wicksten 1983: 28 (in part); Wicksten 1990: 596 (in part); Hendrickx and Wicksten 1992: 7 (in part). Not *Hippolysmata intermedia* Kingsley, 1878.

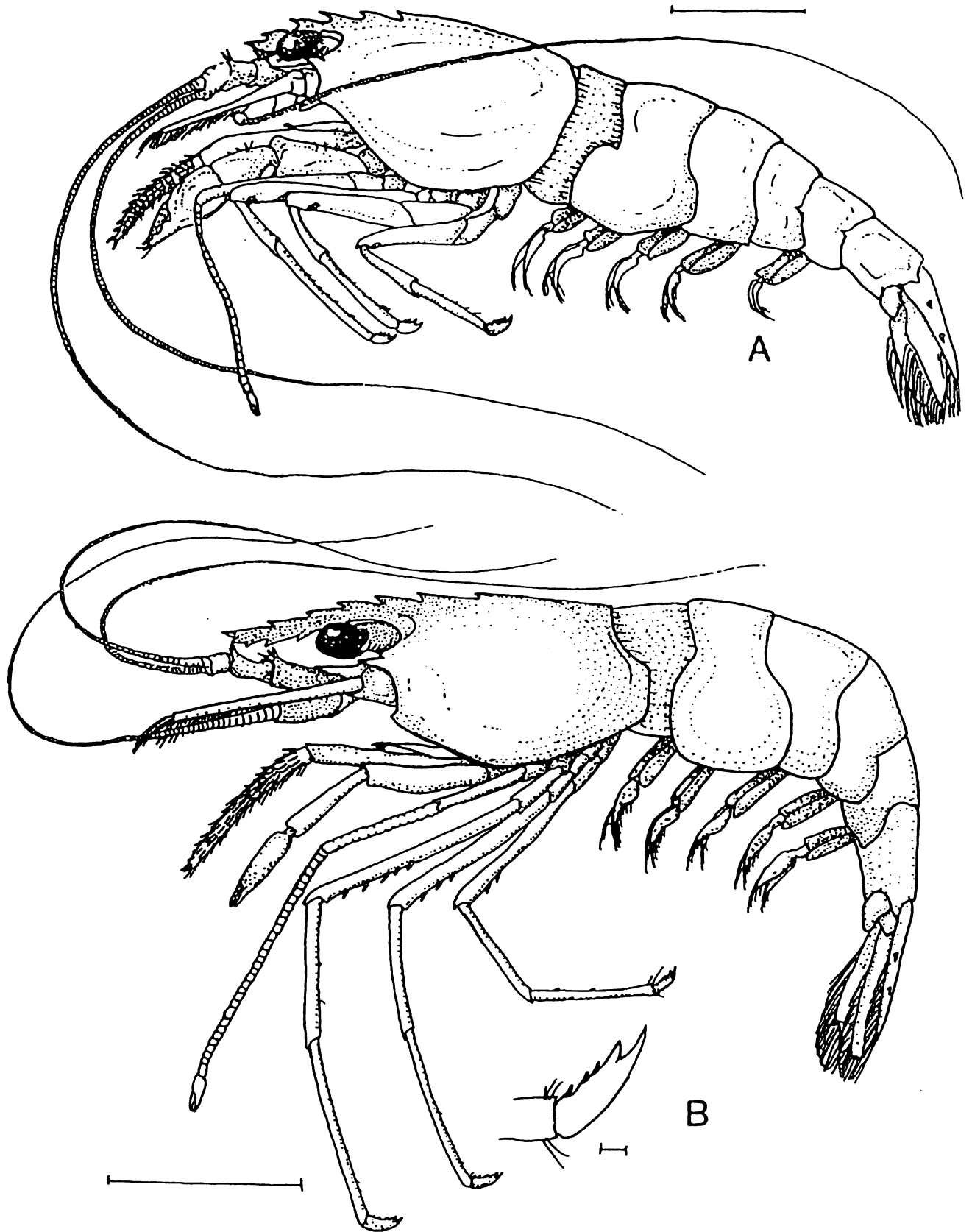

Fig. 8. A, *Lysmata porteri* (Rathbun). Male, CL 8.7, Cumberland Bay, Islas Juan Fernández, Chile; B, *Lysmata gracilirostris* Wicksten. Female, CL 6.3, Gulf of Papagayo, Costa Rica; with detail of dactyl of third pereopod. Scales A, B=5 mm; scale C= 2 mm.

Material examined. HOLOTYPE: female, ov. CL 14.5; Playa Mantachen, about 5 mi. SE of San Blas, Nayarit, Mexico (21° 33' N, 105° 19' W); 21 Dec. 1961, J.R. Paxton number JRP-28-8, LACM cat. no. 61-174.1. PARATYPES: female, ov., CL 14.7, same location, date and collector as holotype, LACM. 4 females, CL 7.4-8.9, 1 of them ov.; Same location, December 1961, Gary Brusca, LACM. Broken specimen, CL 2.6; Canal Zone, Panama, on dry dock, 6 March 1937, S.F. Hildebrand, USNM cat. no. 237446.

Description. Rostrum (Fig. 9A-C) slightly shorter than, to slightly exceeding, second segment of antennular peduncle, with prominent lateral carina, 6-7 dorsal teeth, (one of them on the carapace, six on the rostrum proper) and 3-6 ventral teeth; lower margin convex. Carapace (Fig. 9A-B) with anterior margin convex above sharp antennal spine; no pterygostomian spine, pterygostomian area bluntly rounded. First to fourth abdominal somites (Fig. 9B) with margins of pleura rounded or obtuse. Pleuron of fifth somite with sharp distolateral point, sixth somite with points at distoventral and distolateral angles (Fig. 9B). Telson (Fig. 9E) about 0.75X length of uropods, with 2 pairs of dorsolateral spines, 3 pairs terminal spines and slight terminal point.

Stylocerite (Fig. 9A-C) about 0.75X length of first segment of antennular peduncle. First segment with few soft setae on distal surface. Second segment shorter than first segment, third shortest of all. Accessory branch of outer antennular flagellum completely fused with other branch or with 1-2 free articles, fixed branch with 29-31 articles. Flagella long, reaching abdomen when extended.

Basicerite with small ventrolateral spine. Scaphocerite longer than antennular peduncle by about 0.25X of its length, blade and spine nearly equal in length, blade somewhat rectangular (not tapering). Flagella longer than entire body.

Mouthparts as figured (Fig. 11). All maxillipeds with exopods. Third maxilliped (Fig. 11A) with epipod, exopod less than 0.5X length of antepenultimate segment. Penultimate segment about 0.5X length of antepenultimate segment. Ultimate segment setose, about 1.3 X length of penultimate segment, with 4 terminal claws. When extended, third maxilliped exceeding length of scaphocerite by about 0.5X length of its ultimate segment.

First to fourth pereopods (Fig. 10A-D) with epipods. First pereopod (Fig. 10A) chelate, dactyls 0.5 X length of palm. Carpus about as long as palm. Merus slightly longer than carpus, its lower margin convex along proximal end. Ischium short. Second pereopod (Fig.

10B) long and slender, chelate. Fingers of chela shorter than length of palm. Carpus with 22-26 articles, merus with 15-18 faint annulations, ischium with 4-5 faint annulations. Third to fifth pereopods (Fig. 10C-E) similar, but decreasing in size posteriorly. Third pereopod (Fig. 10C) with dactyl short, about 0.25X length of propodus, with 2 terminal claws and 2 smaller spines (Fig. 10 F). Propodus with 5-7 spinules, occurring singly or in pairs. Carpus about the same length as propodus, with 2 minute spinules on flexor margin. Merus 3X length of ischium, with 6 ventrolateral spines. Fourth pereopod (Fig. 10D) with 5-6 ventrolateral meral spines, fifth pereopod (Fig. 10E) with 4-5 ventrolateral meral spines.

Second pleopod (Fig. 9D) with appendix interna. Lateral branch of uropod (Fig. 9E) with fixed tooth beside movable spine. Female carapace length to 14.7 mm. Male not known.

Color in life. Not reported.

Range. Playa Mantachen, Nayarit, Mexico, to Canal Zone, Panama.

Etymology. The species is named for the state of Nayarit on the western coast of Mexico.

Remarks. *Lysmata nayaritensis* most closely resembles *L. californica* (Stimpson, 1866) and *Lysmata porteri* (Rathbun, 1907). In all three species, the accessory branch of the antennular flagellum is nearly completely fused with the principal branch. However, neither *L. californica* nor *L. porteri* has a convex lower margin to the rostrum. *Lysmata californica* has 5-7 dorsal teeth and 2-3 ventral teeth on the rostrum; there are 25-32 (usually 27-29) carpal articles of the second pereopod. *Lysmata californica* (carapace length 18.2 mm) grows larger than *L. nayaritensis*. In life, *L. californica* is marked with longitudinal stripes and blotches of red. *Lysmata porteri* has massive chelae. The second pereopod has 6 dorsal and 1-2 ventral rostral teeth and 21-22 carpal articles. Neither species is known to occur within the range of *L. nayaritensis*.

Lysmata porteri (Rathbun, 1907)

Fig. 8A

Hippolysmata Porteri Rathbun, 1907: 49, pl.3, fig. 4.
Hippolysmata porteri Rathbun 1910: 605; Balss 1924: 332; Porter 1937: 258, fig. 30; Holthuis 1947: 19; Holthuis 1952: 66; Wicksten 1979: 629.
Lysmata porteri Chace 1997: 74; Wicksten 1990: 596.

Material examined. CHILE, JUAN FERNANDEZ ISLANDS: 2 females, CL 11.7-12.0, both ov., 16 males, CL

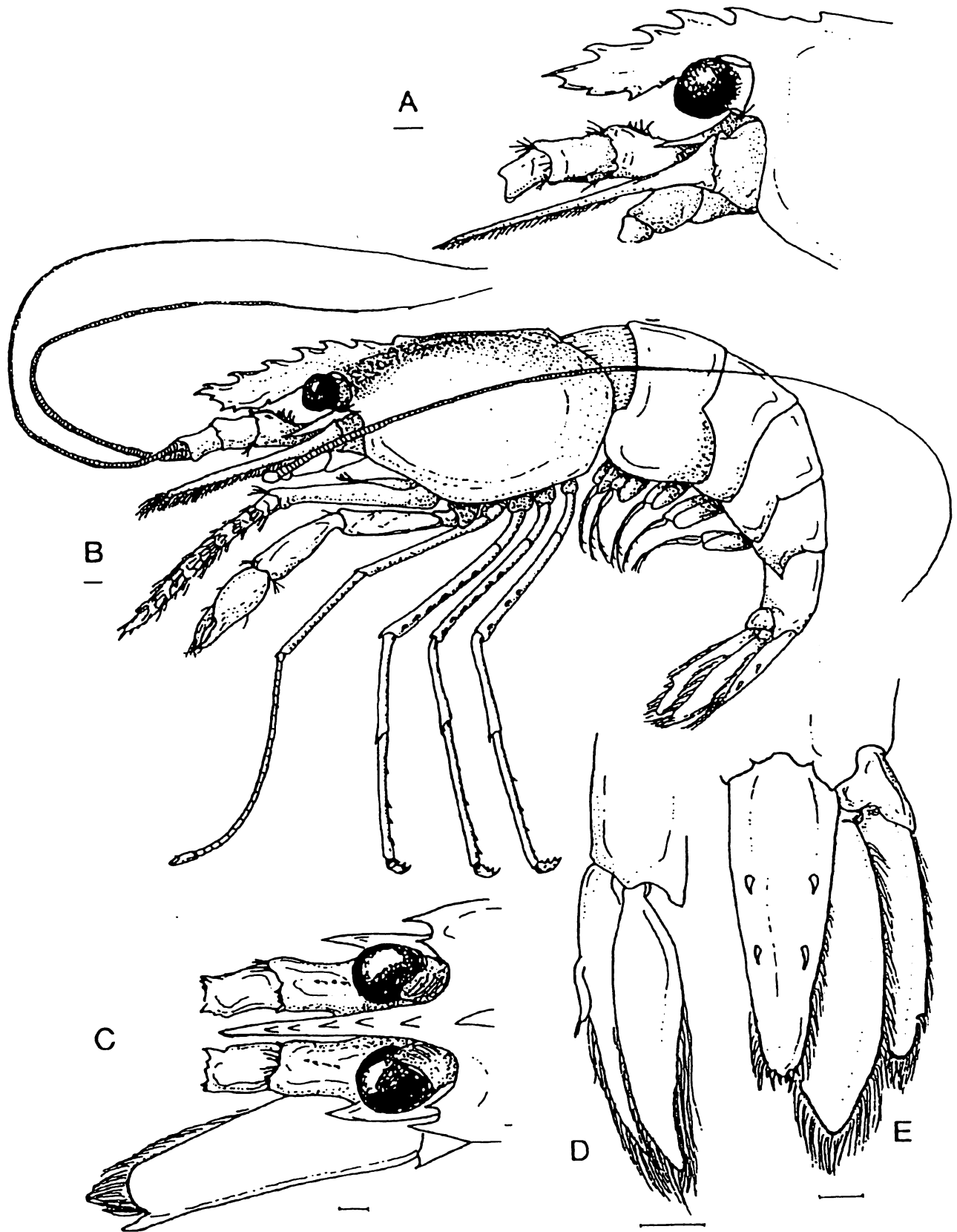

Fig. 9. *Lysmata nayaritensis* n. sp. Female, CL 14.7, Mantachen Beach, Nayarit, Mexico. A, frontal region in lateral view; B, entire animal in lateral view; C, frontal region in dorsal view; D, second pleopod; E, telson and uropod. Scales = 1 mm.

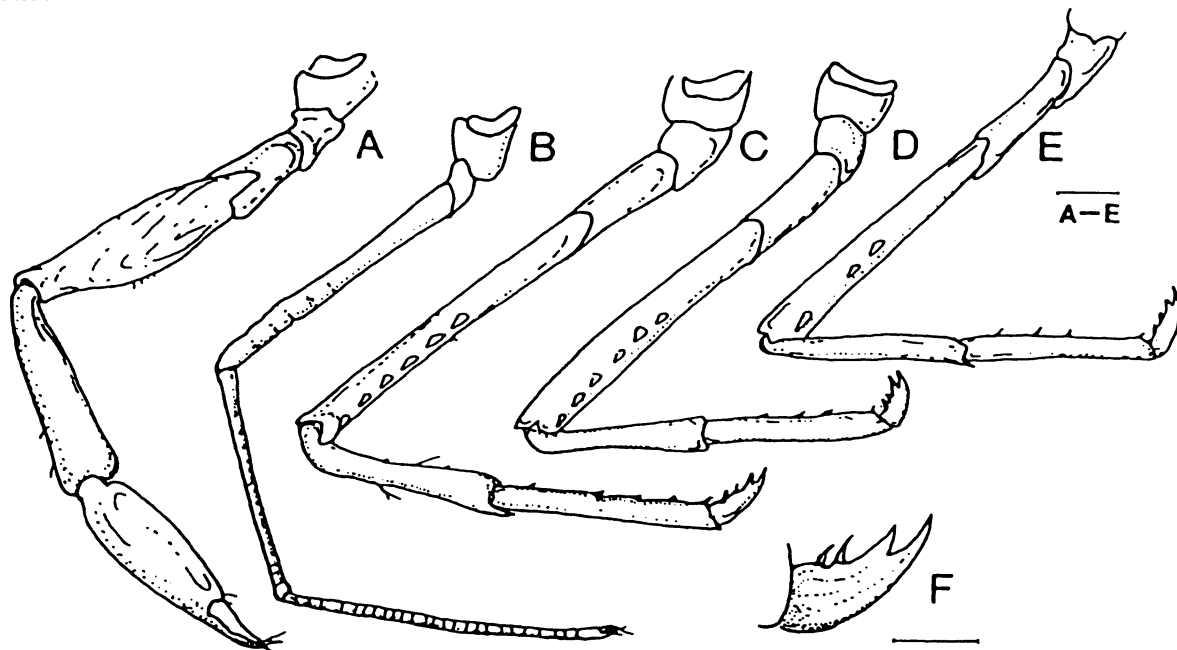

Fig. 10. *Lysmata nayaritensis* n. sp. Female, CL14.7, Mantachen Beach, Nayarit. A, first pereopod; B, second pereopod; C, third pereopod; D, fourth pereopod; E, fifth pereopod; F, detail of dactyl of third pereopod. Scales = 1 mm.

4.2-7.8; Bahía Villagra, 15 Dec. 1965, depth not given, SIO C2613. 6 males, CL 6.5-8.7; Bahía Cumberland, 0-3 m, 11 Dec. 1968, W. Baldwin, SIO C3448. 2 females, CL 3.7-6.6; 5 males, CL 6.1-10.0 [1 carapace only, 3.1 and fragment]; SW of West Bay, 0-5 m, SCUBA, 12 Dec. 1965, B.W. Walker and party, SIO C2417.

Recognition characters. Rostrum with 5-6 dorsal and 1-2 ventral teeth, slightly concave beneath. Carapace with slight lobe below orbit just above strong antennal spine, no pterygostomial spine, pterygostomial margin obtuse. Stylocerite not reaching end of first segment of antennular peduncle. First segment of antennular peduncle longest of three, with curved spinules at distal margin; second shortest; with small spinules on distal margin. Accessory branch of outer antennular flagellum entirely fused, fused part consisting of 18-19 articles. Basicerite of second antenna with minute lateral spine. Thickened base of antenna reaching beyond first segment of antennular peduncle. Scaphocerite 3X as long as wide, with spine distinctly exceeding blade, longer than antennular peduncle by about 0.3X of its length. Third maxilliped with exopod reaching about to midlength of antepenultimate segment. First pereopod unusually robust; palm of chela 2.7X long as wide, fixed finger and movable finger of chela each with one low tooth fitting into concavity on opposing finger, tips of fingers curved. Second pereopod elongate, with small chela and 20-24 carpal articles. Third to fifth pereopods similar; third pereopod largest of these;

dactyl short, curved and biunguiculate with 2 smaller spines on flexor margin, few spinules on propodus. Third pereopod with 2-3 ventrolateral meral spines; fourth pereopod, with 1-2; fifth pereopod, with 1. Male carapace length to 10.0, female to 12.0 mm. Color in life. Not reported.

Habitat. Low intertidal to 12 m, rocks.

Range. Chile: Bay of Valparaíso, Lota, Arauco Bay, south of Concepción, Islas Juan Fernández. Type locality Bay of Valparaíso (Rathbun, 1907).

Lysmata trisetacea (Heller, 1861)

(Fig. 12)

Hippolyte trisetacea Heller, 1861: 29.

Hippolysmata paucidens Rathbun, 1906: 913, pl. 24, fig. 4.

Lysmata chiltoni Kemp, 1914: 110, pl. 6, figs. 1-4.

Lysmata paucidens Schmitt 1939: pl. 12.

Lysmata trisetacea Holthuis 1947: 19, 65; Chace 1962: 614; Abele 1975: 81; Wicksten 1983: 27; Wicksten 1990: 596; Chace 1997: 72 (see this reference for a more complete synonymy).

Material examined. MEXICO: 6 females, CL 2.8-8.0, 3 of them ov., 2 males, both CL 3.6, Calerita, Baja California Sur, shore, among corals, 23 July 1997, Ricardo Pereyra, Luis Hernández and party, UBCS. 2 females, CL 4.7-4.8, 1 of them ov., Roca Pelicano, Cabo San Lucas, Baja California, 2-5 m, 26 July 1997, Carlos Sánchez and party, UBCS. 3 females, CL 4.8-5.1, all ov., 2 males, CL 3.0-3.7, 2 frag-

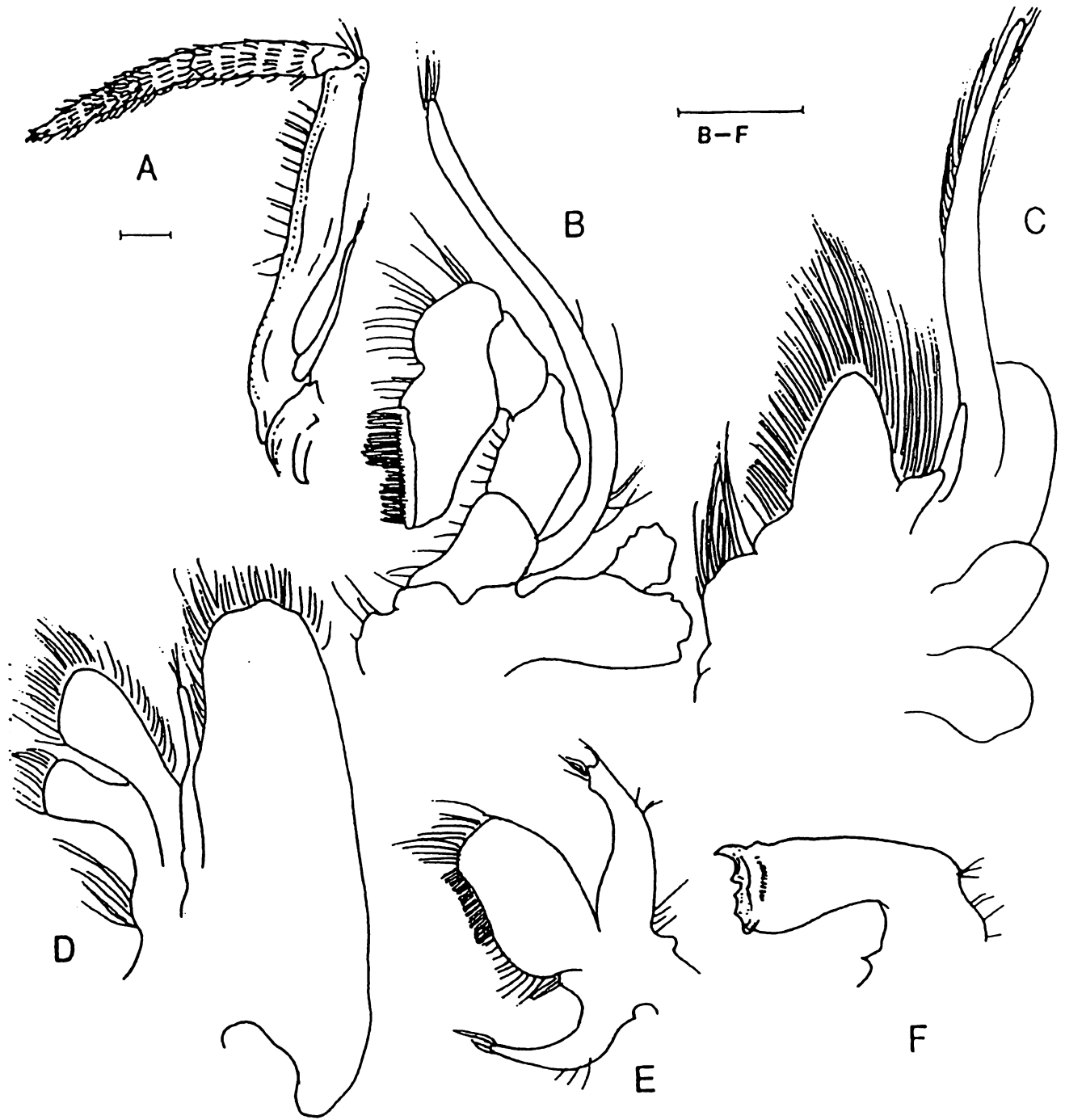

Fig. 11. *Lysmata nayaritensis* n. sp. Female, CL 8.5, Mantachen Beach, Nayarit. A, third maxilliped; B, second maxilliped; C, first maxilliped; D, second maxilla; E, first maxilla; F, mandible. Scales = 1 mm.

ments, CL 3.6-4.5, Bahía Sulphur, Isla Clarion, rocks and tide pools, shore, 10 June 1934, Yelero III sta. 298-35, LACM. Male, CL 4.0. Bahía Braithwaite Bay, Isla Socorro, 3 Jan. 1934, Yelero III sta. 131-34, LACM. HAWAIIAN ISLANDS: 2 females, CL 5.0-5.4, both ov., fragment, CL 5.0, Pukee, Molokai, reef, USNM 48958. Female, CL 4.6, Honolulu, Hawaii, 1901, USNM 25410. 4 females, CL 3.7-4.8, 3 of them ov., intersex, CL 2.9, Laysan, May 1902, USNM 30981.

Recognition characters. Rostrum with 3-5 dorsal and 1-3 ventral teeth, reaching slightly beyond end of first segment of antennular peduncle. Carapace with antennal spine, no pterygostomian spine, pterygostomian area rounded. Stylocerite as long as or longer than first segment of antennular peduncle. First segment of antennular peduncle with tuft of setae on distal margin. Accessory branch of outer antennular flagellum with 7-

10 free articles, all wide and densely setose, and 12-17 fused articles. Basicerite with well developed lateral spine. Scaphocerite broad and short, 3X long as wide, spine about as long as blade, sometimes barely exceeding it. Third maxilliped with exopod reaching to or just shorter than antepenultimate segment. First to fourth pereopods with epipods. Second pereopod with 19-26 carpal articles, 12-15 meral annulations and 3-4 faint ischial annulations. Dactyls of third to fifth pereopods biunguiculate and short, with 2 spines on flexor margin. Merus of third pereopod with 3-4 ventrolateral spines, fourth pereopod, with 2-3; fifth pereopod, with at most 2 spines. Carapace length of female to 8.0, male to 4.0 mm.

Color in life. Reddish, with pattern of red lines run-

ning lengthwise on carapace and faint red bands on abdomen against translucent yellowish background; without prominent dark blotches, lines or silvery spots. (Notes based on female specimen from Cabo San Lucas).

Habitat. Among rock, shells, coral, intertidal to 150 m.
Range. Calerita, Cabo San Lucas, Gulf of California; Acapulco, Guerrero; Clarion and Socorro Islands, Mexico; Clipperton Island, Malpelo Island, Colombia; Indo-Pacific region from Red Sea to Hawaiian Islands; New Zealand. Type locality Red Sea (Heller, 1861).

Remarks. In the keys given by Wicksten (1983, 1990), the species is said to have "12" ventral rostral teeth. This is a typographical error, and it should read "1-2".

Key to the Eastern Pacific Species of *Lysmata*

1. Outer antennular flagellum with distinct accessory branch of at least 3 articles. Stylocerite at least as long as first segment of antennular peduncle. 2
 Outer antennular flagellum with accessory branch fused or vestigial, consisting of no more than 2 free articles. Stylocerite not as long as first segment of antennular peduncle 5.
2. Accessory branch of outer antennular flagellum free for about half of its length, generally with 7-17 free articles. Rostrum with 3-5 dorsal teeth 3.
 Accessory branch of outer antennular flagellum free for less than half of its length, generally with 7 or fewer free articles. Rostrum with 5-7 dorsal teeth 4.
3. Spine of scaphocerite longer than blade, blade 4X long as wide. *Lysmata argentopunctata* n. sp.
 Spine of scaphocerite about as long as blade, blade 3X long as wide. *Lysmata trisetacea* (Heller)
4. Rostrum with seta between posterior teeth on carapace. Carpus of second pereopod with 17-19 carpal articles *Lysmata galapagensis* Schmitt
 Rostrum without setae between posterior teeth on carapace. Carpus of second pereopod with 23-27 carpal article. *Lysmata chica* n.sp.
5. Carpus of second pereopod with 25 or more carpal articles. (Ranging from California, U.S.A. to central Baja California and northern Gulf of California, Mexico). 6.
 Carpus of second pereopod with less than 25 carpal articles. (Ranging from southwestern Mexico to Galapagos I Islands) 7.
6. Rostrum with 2-4 ventral teeth. Dactyl of third pereopod short, merus with 6-7 spines. (Ranging from California, U.S.A. to Gulf of California) *Lysmata californica* (Stimpson)
 Rostrum with 5-6 ventral teeth. Dactyl of third pereopod elongate, merus with 3 spines. (Ranging from Socorro Island, Mexico to Galapagos Islands) *Lysmata gracilirostris* Wicksten
7. Rostrum convex on lower border, with 6-7 dorsal and 3-6 (usually 4) ventral teeth. Fingers of chela of first pereopod without teeth. (Ranging from western Mexico to Panama)
 *Lysmata nayaritensis* n. sp.
 Rostrum relatively straight on lower border, with 6 dorsal and 2 ventral teeth. Fingers of chela of first pereopod with teeth. (Ranging from Chile to Juan Fernandez Islands)
 *Lysmata porteri* Rathbun

Literature Cited

ABELE, L. G. 1975. The macruran decapod Crustacea of Malpelo Island. Smithsonian Contrib. Zool. 176: 69-85.
 BALSS, H. 1924. Decapoden von Juan Fernandez. In: Skottsberg, C. The Natural history of Juan Fernandez and Easter Island, vol.3: 329-340.
 BRUSCA, R. C. 1980. Common intertidal invertebrates of the Gulf of California. University of Arizona Press, Tucson, Arizona: Second edition, 513 pp
 CHACE, F. A. Jr., 1962. The non-brachyuran decapod crustaceans of Clipperton Island. Proc. U. S. Nat.

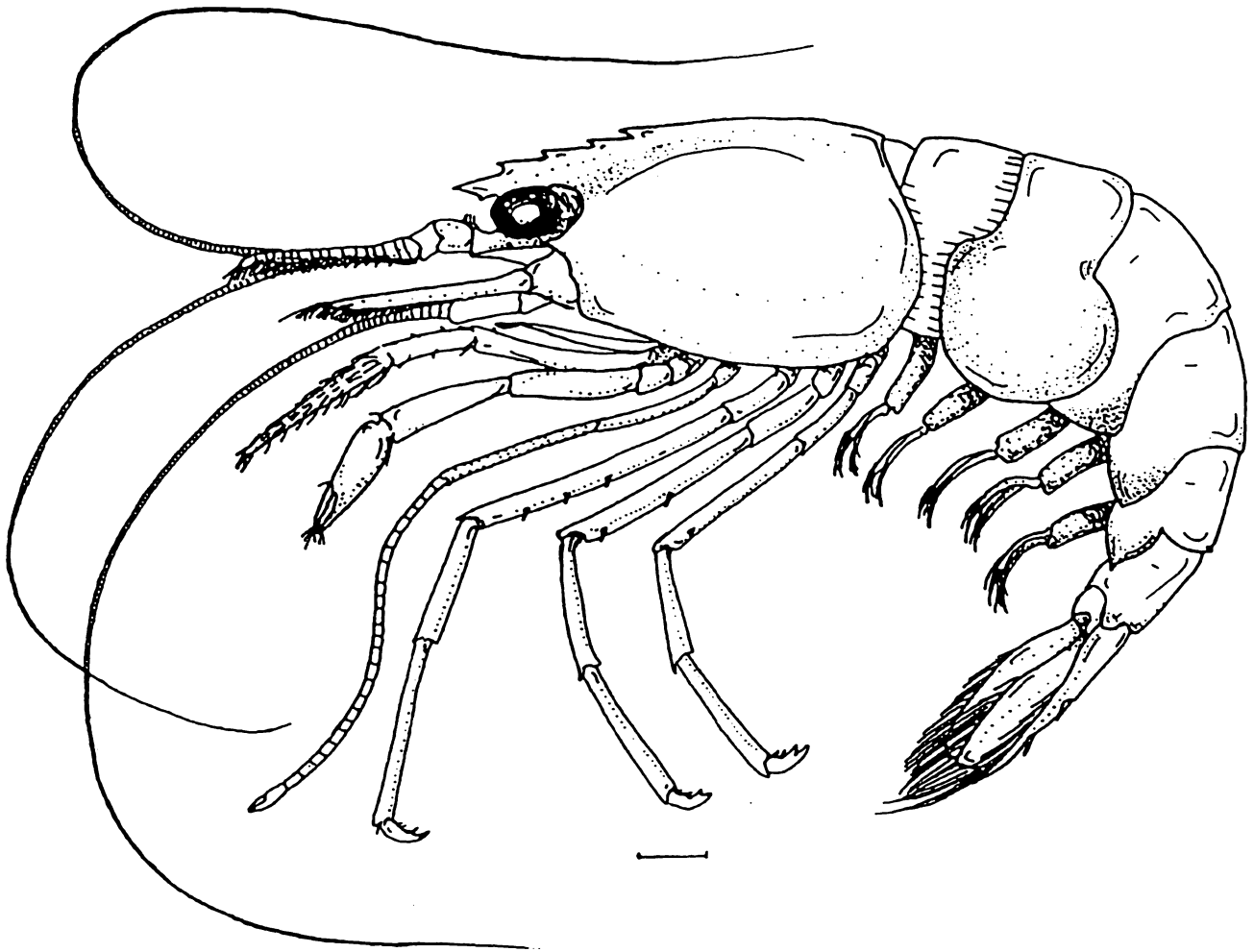

Fig.12. *Lysmata trisetacea* (Heller). Female, CL 5.5, Calerita, Baja California, Mexico. Scale = 1 mm.

- Mus. 113 (34660): 605- 635.
- CHACE, F. A. Jr. 1972. The shrimps of the Smithsonian-Bredin Caribbean Expeditions with a summary of the West Indian shallow-water species (Crustacea: Decapoda: Natantia). *Smithsonian Contrib. Zool.* 98: 1-179.
- CHACE, F. A. Jr. 1997. The caridean shrimps (Crustacea: Decapoda) of the *Albatross* Philippine Expedition, 1907-1910, Part 7: Families Atyidae, Eugeonatonotidae, Rhynchocinetidae, Bathypalemonellidae, Processidae, and Hippolytidae. *Smithsonian Contrib. Zool.* 587: 1-106.
- CHACE, F. A. Jr. and D. P. ABBOTT 1980. Caridea: the shrimps. In Morris, R. H., D. P. Abbott and E. C. Haderlie, eds. *Intertidal invertebrates of California*. Stanford: Stanford University Press. p. 567-576.
- DEBELIUS, H. 1984. *Armored knights of the sea*. Essen: Alfred Kernen Verlag. 120 pp.
- HELLER, C. 1861. *Synopsis der im rothen Meere- vorkommenden Crustaceen*. Verhandlungen der Kaiserlich-königlichen Zoologisch-botanisch Gesellschaft in Wien 11: 3-32.
- HENDRICKX, M. E. 1989. On a small collection of caridean shrimp (Crustacea:Decapoda) from the Barra de Navidad coastal lagoon, Jalisco, Mexico. *Anal. Inst. Cienc. Mar. Limnol., Universidad Nacional Autónoma de México* 15(1): 245-248.
- HENDRICKX, M. E., and M. K. WICKSTEN 1987. Studies of the coastal marine fauna of southern Sinaloa. VIII. Additional report on the caridean crustaceans. *Annal. Inst. Cienc. Mar. Limnol., Universidad Nacional Autónoma de México* 14 (1): 13-20.
- HOLMES, S. J. 1900. Synopsis of California stalk-eyed Crustacea. *Occ. Papers Calif. Acad. Sci. ser. 2, 4*: 563-588.
- HOLTHUIS, L. B. 1947. The Hippolytidae and Rhynchocinetidae collected by the Siboga and Snellius

- Expeditions with remarks on other species. The Decapoda of the Siboga Expedition. Part IX. Siboga Expeditie Mon. 39a: 1-100.
- HOLTHUIS, L.B. 1952. The Crustacea Decapoda Macrura of Chile. Reports of the Lund University Chile Expedition 1948-49. Lunds Universitets Arsskrift, N.F. avd. 2, 47, (10): 109 pp.
- HULT, J. 1939. Crustacea Decapoda from the Galapagos Islands collected by Mr. Rolf Blomberg. Ark. Zool. 30A(5): 1-18.
- JENSEN, G. C. 1995. Pacific coast crabs and shrimps. Sea Challengers, Monterey, California. 87 pp.
- KEMP, S. 1914. Notes on Crustacea Decapoda in the Indian Museum. V. Hippolytidae. Rec. Indian Mus. 10, 2 (4): 81-129.
- KERSTITCH, A. 1989. Sea of Cortez marine invertebrates. Sea Challengers, Monterey, California. 114 pp.
- KINGSLEY, J. S. 1878. Notes on the North American Caridea in the Museum of the Peabody Academy of Science at Salem, Massachusetts. Proc. Acad. Nat. Sci. Philadelphia 1878: 89-98.
- LIMBAUGH, C. 1961. Cleaning symbiosis. Sci. Am. 205(2): 42-49.
- PORTER, C. E. 1937. Sobre algunos Decapodos raros o poco conocidos. Carcinologia Chilena XXVI. Revista Chilena Hist. Nat. 40: 252-259.
- RATHBUN, M. J. 1904. Decapod crustaceans of the northwest coast of North America. Harriman-Alaska Expedition 10: 3-210.
- RATHBUN, M. J. 1906. The Brachyura and Macrura of the Hawaiian Islands. Bull. U. S. Fish. Comm. 23(3): 827-930.
- RATHBUN, M. J. 1907. South American Crustacea. Revista Chilena Hist. Nat. 11: 45-50.
- RATHBUN, M. J. 1910. The stalk-eyed Crustacea of Peru and the adjacent coast. Proc. U. S. Nat. Mus. 38: 531-620.
- RICKETTS, E. F., J. CALVIN, J. HEDGPETH and D.W. PHILLIPS. 1985. Between Pacific tides. Stanford University Press, Stanford, California. Fifth edition, 652 pp.
- SCHMITT, W. 1921. The marine decapod Crustacea of California. Univ. Calif. Publ. Zool. 23: 1-470.
- SCHMITT, W. 1924. The Macrura and Anomura collected by the Williams Galapagos Expedition, 1923. Zoologica 5: 161-171.
- SCHMITT, W.L. 1939. Decapod and other Crustacea collected on the presidential cruise of 1938. Smithsonian Inst. Misc. Coll. 98(6): 1-29.
- SIVERTSEN, E. 1933. The Norwegian Zoological Expedition to the Galapagos Islands 1925, conducted by Alf Wollebaek. VII. Littoral Crustacea Decapoda from the Galapagos Islands. Medd. Zool. Mus., Oslo 38: 1-23.
- STANDING, J. D. 1981. Occurrences of shrimps (Natantia: Penaeidea and Caridea) in central California and Oregon. Proc. Biol. Soc. Washington 94(3): 774-786.
- STIMPSON, W. 1866. Descriptions of new genera and species of macrurous Crustacea from the coasts of North America. Proc. Chicago Acad. Sci. 12: 46-48.
- WICKSTEN, M. K. 1979. Zoogeographical affinities of the broken back shrimp (Caridea: Hippolytidae) of western South America. In Proceedings of the International Symposium on Marine Biogeography and Evolution in the Southern Hemisphere. Auckland, New Zealand, 17-20 July, 1978. New Zealand DSIR Information Series 137, 2: p. 627-635.
- WICKSTEN, M.K. 1983. A monograph on the shallow water caridean shrimps of the Gulf of California, Mexico. Allan Hancock Monogr. Mar. Biol. 13: 1-59.
- WICKSTEN, M.K. 1990. Key to the hippolytid shrimp of the eastern Pacific Ocean. U.S. Fish. Bull. 88: 587-598.
- WICKSTEN, M.K. 1991. Caridean and stenopodid shrimp of the Galápagos Islands. In James, M. J. ed. Galápagos Marine Invertebrates. New York: Plenum Publishing. p. 147-156.
- WICKSTEN, M.K. 1996. Decapod crustaceans and pycnogonids of Rocas Alijos. In Schmieder, R. W. ed. Rocas Alijos. Dordrecht, The Netherlands: Kluwer Academic Publishers. p. 285-293.
- WICKSTEN, M.K. 2000. A new species of *Lysmata* (Caridea: Hippolytidae) from the eastern Pacific. Crustaceana 73: 207-213.
- WICKSTEN, M. K. and M. E. HENDRICKX. 1992. Checklist of penaeoid and caridean shrimps (Decapoda: Penaeoidea, Caridea) from the Eastern Tropical Pacific. Proc. San Diego Soc. Nat. Hist. 9: 1-11.
- WICKSTEN, M.K. and M. MÉNDEZ. 1983. Nuevos registros de camarones carideos en el Perú. Bol. etin de Lima 25: 75-89.